



# Parts Manual



## Self Propelled Mower

### Models

Mfg. No.	Description
2691212-00	EQ500, Murray 18" Self Propelled Walk Behind Mower (2014)

Manual Part No. 1758406

Revision -

Rev. Date: 3/18/2014

Not for  
Reproduction

<b>PRODUCT COMPONENTS</b>	<b>PAGES</b>
Handles Group .....	4
Engine & Blade Group .....	6
Deck Group .....	8
Drive Group .....	10
<b>Torque Specification Chart .....</b>	<b>Inside Back Cover</b>

Not for  
Reproduction

## Handles Group

NOTE: Unless noted otherwise,  
use the standard hardware torque  
specification chart.

2691212handle

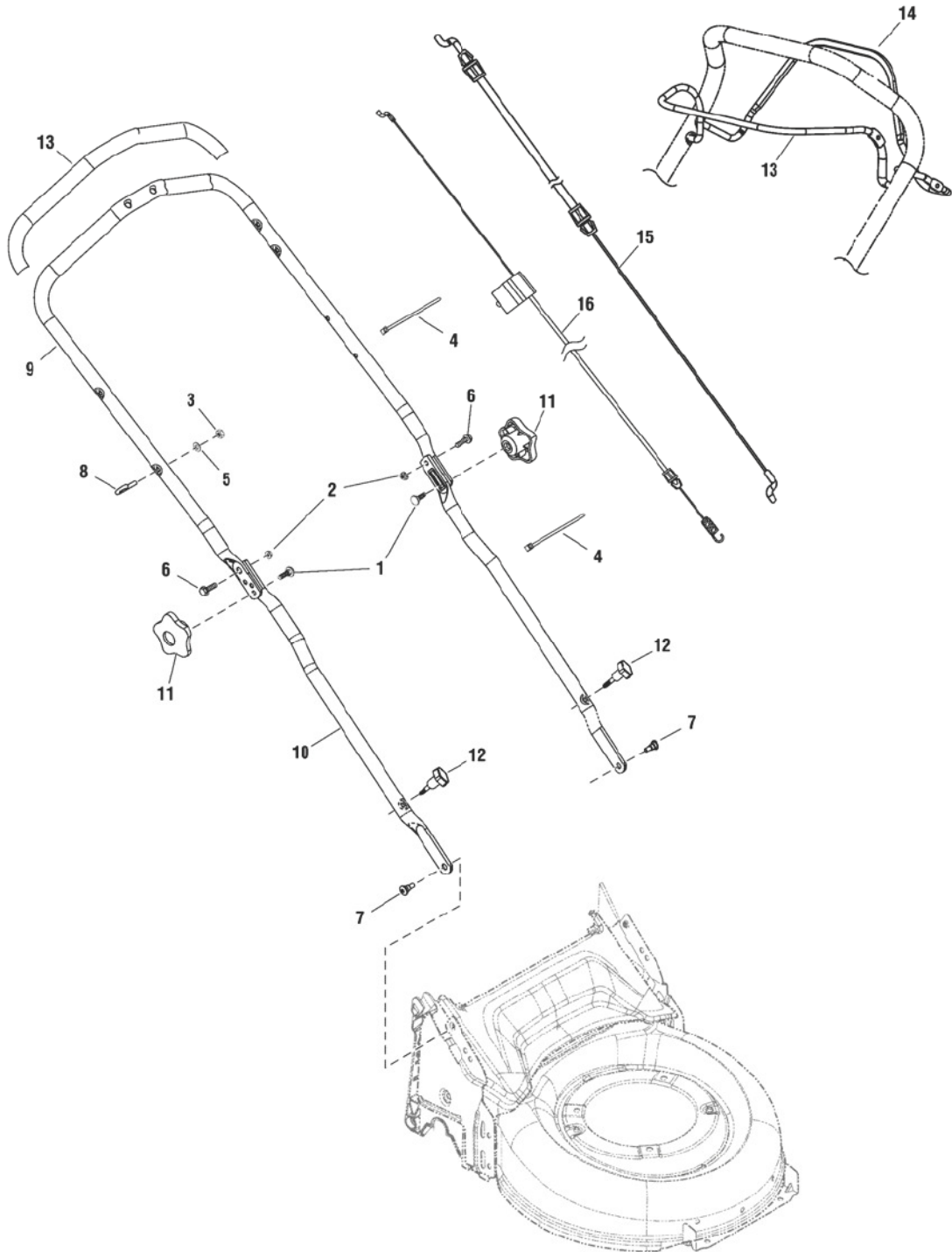

The above parts group applies to the following Mfg. Nos.:  
2691212-00 - EQ500

### Handles Group

REF NO	PART NO.	QTY	DESCRIPTION
1	703483	2	BOLT, 5/16-18 x 1 G5
2	703463	2	NUT, Flange, 1/4-20
3	67885GS	1	NUT, Nylock, M6
4	704774	2	CABLE CLIP
5	703781	1	WASHER, A6.4
6	703522	2	SCREW, 1/4-20
7	704729	2	BOLT, Shoulder
8	704695	1	BOLT, Eye
9	704706	1	HANDLE, Upper
10	704708	2	HANDLE, Lower
11	704776	2	WING KNOB, 5/16-18
12	704779	2	WING KNOB
13	704715	1	BAIL, Control
14	704718	1	BAIL, Drive
15	704723	1	CABLE, Control
16	704720	1	CABLE, Drive
17	704778	1	GRIP

Not for  
Reproduction

### Footnotes

---

The above parts group applies to the following Mfg. Nos.:  
2691212-00 - EQ500

## Engine & Blade Group

2691212engine

NOTE: Unless noted otherwise,  
use the standard hardware torque  
specification chart.

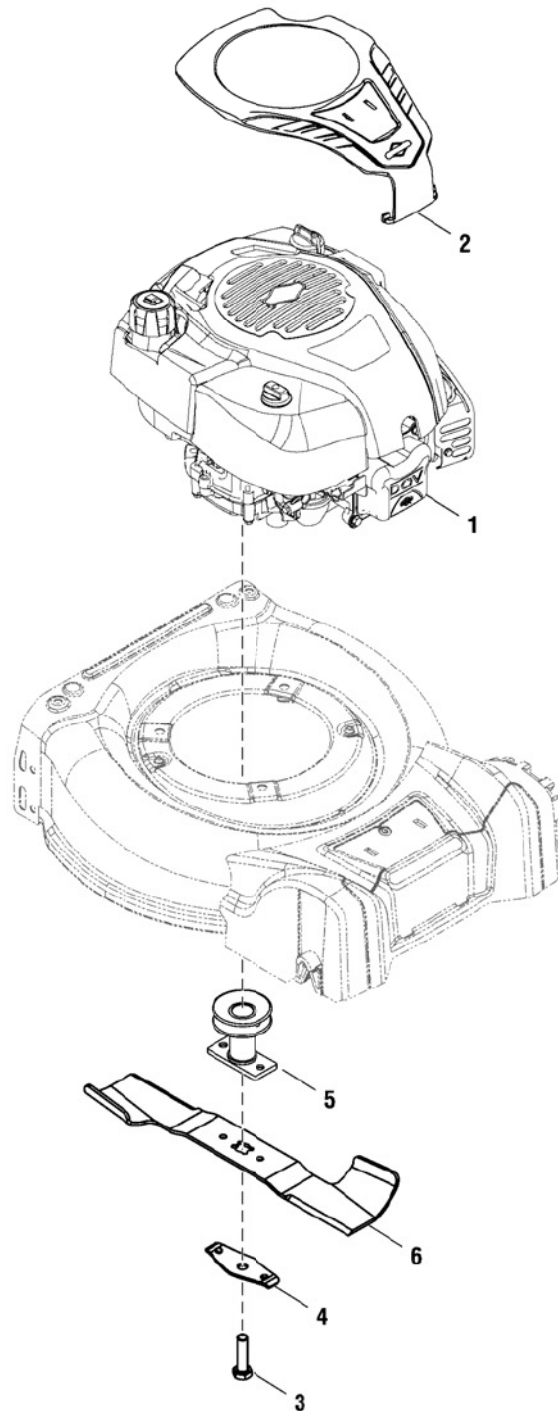

The above parts group applies to the following Mfg. Nos.:  
2691212-00 - EQ500

## **Engine & Blade Group**

<b>REF NO</b>	<b>PART NO.</b>	<b>QTY</b>	<b>DESCRIPTION</b>
1	09P602-0004-H1	1	* ENGINE, Briggs & Stratton, Mod. 09P702-0103-H1 (Engine Model: 09P602-0004-H1)
2	704704	1	SHROUD
3	704785	1	SCREW Hex, 3/8-24 x 1-1/2
4	703520	1	SUPPORT, Blade Bell
5	703618	1	BLADE ADAPTER
6	704726	1	BLADE

Not for  
Reproduction

### **Footnotes**

Note\* To verify your specific engine model, please reference the ID Tag located on your engine. See your local Briggs & Stratton distributor for parts and service.

---

**The above parts group applies to the following Mfg. Nos.:**

2691212-00 - EQ500

## Deck Group

NOTE: Unless noted otherwise,  
use the standard hardware torque  
specification chart.

2691212deck

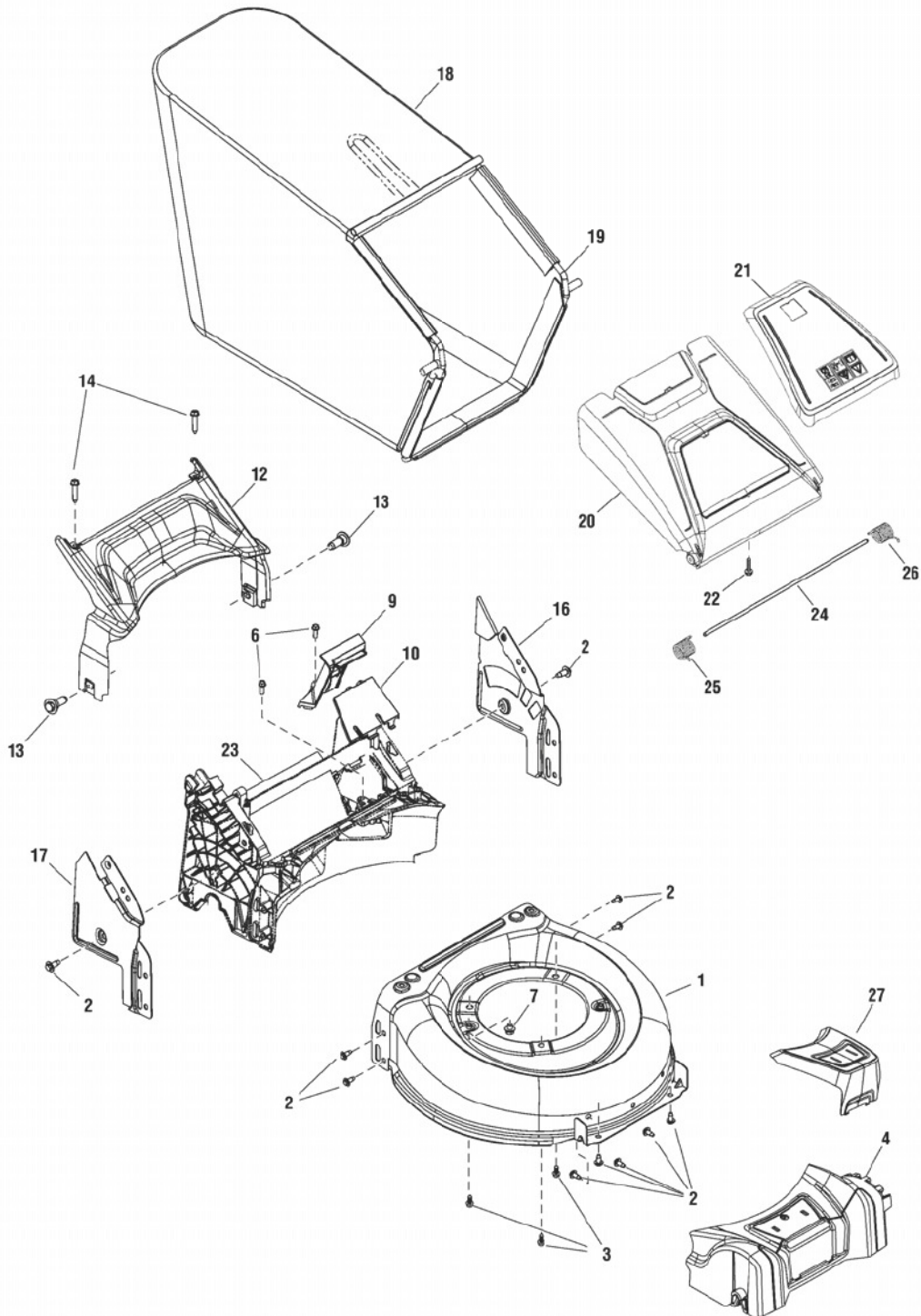

The above parts group applies to the following Mfg. Nos.:  
2691212-00 - EQ500



## Deck Group

REF NO	PART NO.	QTY	DESCRIPTION
1	704687	1	DECK
2	704787	11	SCREW, Hex Head
3	703407	3	SCREW, 3/8-16 x 1
4	704757	1	FRONT COVER, Deck
6	7091081SM	1	SCREW, 1/4-15 x 3/4
9	704760	1	COVER, Rear
10	704759	1	COVER, Front
12	704756	1	COVER, Rear
13	703523	2	SCREW, 5/16-14
14	704789	2	SCREW, 1/4-15 x 1-1/4
16	704690	1	SUPPORT, Handle, LH
17	704689	1	SUPPORT, Handle, RH
18	704795	1	BAG
19	704800	1	FRAME
20	704763	1	REAR FLAP
21	704747	1	COVER, Gray
22	704786	2	SCREW #10-16 x 3/4
23	704809	1	BAFFLE, Rear
24	704717	1	ROD
25	704735	2	TORSION SPRING, RH
26	704734	2	TORSION SPRING, LH
27	704748	1	INSERT, Front Cover

Not for  
Reproduction

## Footnotes

The above parts group applies to the following Mfg. Nos.:  
2691212-00 - EQ500

## Drive Group

NOTE: Unless noted otherwise,  
use the standard hardware torque  
specification chart.

2691212drive

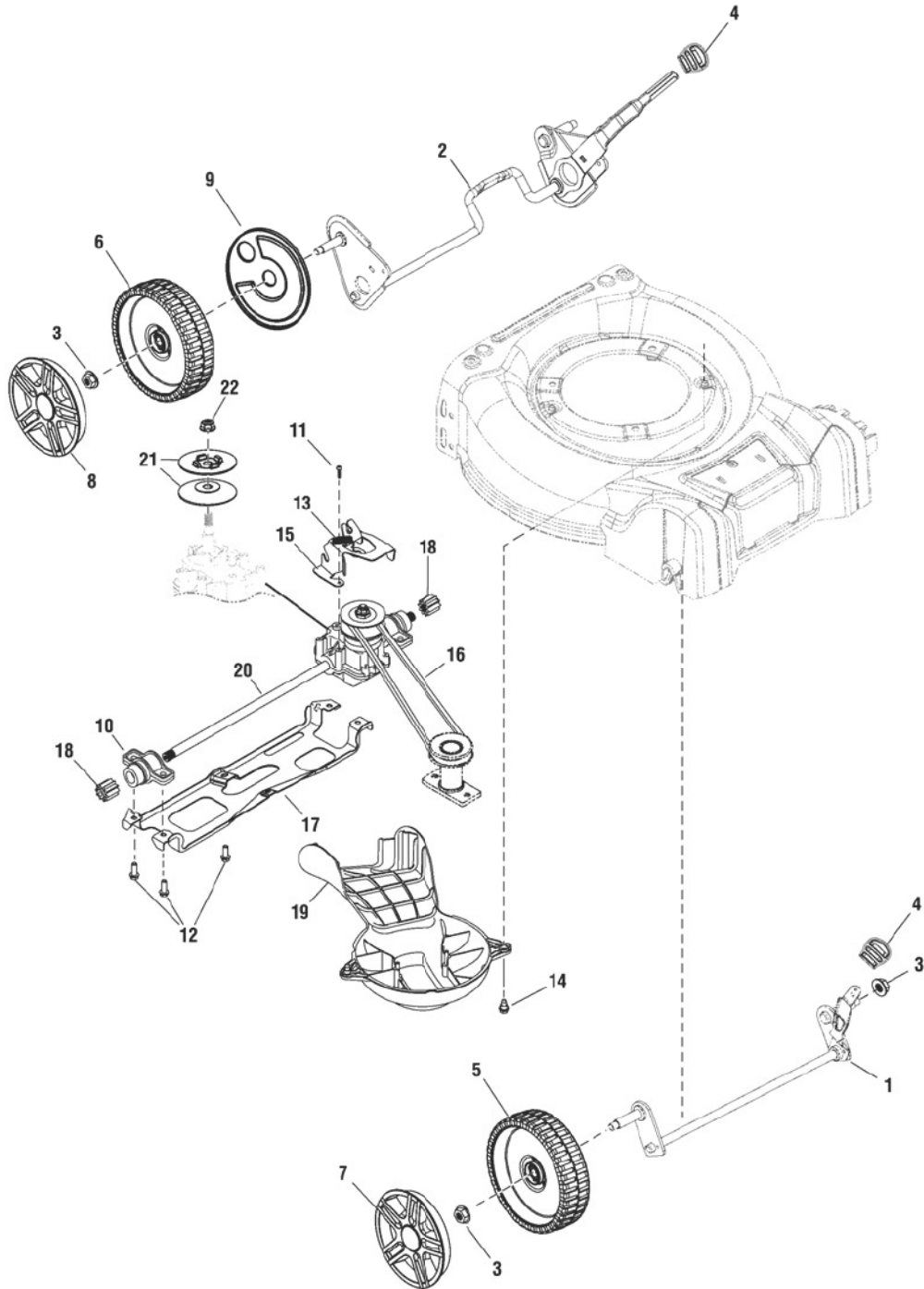

The above parts group applies to the following Mfg. Nos.:  
2691212-00 - EQ500

## Drive Group

REF NO	PART NO.	QTY	DESCRIPTION
1	704827	1	AXLE, Front
2	704822	1	AXLE, Rear
3	5025394SM	4	NUT, Flange, 3/8-16
4	704775	2	KNOB, Adjust
5	704732	2	WHEEL, 180 x 47
6	704806	2	WHEEL, Drive
7	704739	2	HUB CAP, Front
8	704738	2	HUB CAP, Rear
9	703505	2	DUST COVER, Wheel
10	703469	2	BEARING ASSEMBLY
11	703479	2	SCREW, Hex Washer Head, .159 x .43
12	7900023SM	5	SCREW, 1/4-15 x 1-1/4
13	703516	1	SPRING, Extension, 2.675
14	703714	2	SCREW, 1/4-20 x 1/2
15	704694	1	BRACKET
16	704701	1	BELT
17	704688	1	SUPPORT
18	704781	2	GEAR, 10T
19	704813	1	COVER
20	704815	1	TRANSMISSION
21	704698	2	PULLEY HALF
22	704783	1	LOCK NUT

Not for  
Reproduction

## Footnotes

The above parts group applies to the following Mfg. Nos.:  
2691212-00 - EQ500

Not for  
Reproduction

Not for  
Reproduction

Not for  
Reproduction

# Hardware Identification & Torque Specifications

Torque Specification Chart FOR STANDARD METRIC MACHINE HARDWARE (Tolerance ± 20%)								
Property Class	5.6		8.8		10.9		12.9	
	Class 5.6		Class 8.8		Class 10.9		Class 12.9	
Size Of Hardware	in/lbs ft/lbs		in/lbs ft/lbs		in/lbs ft/lbs		in/lbs ft/lbs	
		Nm.		Nm.		Nm.		Nm.
M3	5.88	.56	13.44	1.28	19.2	1.80	22.92	2.15
M4	13.44	1.28	30.72	2.90	43.44	4.10	52.56	4.95
M5	26.4	2.50	60.96	5.75	5.97	8.10	7.15	9.7
M6	44.64	4.3	7.3	9.9	10.3	14	12.1	16.5
M7	5.2	7.1	12.1	16.5	16.9	23	19.9	27
M8	7.7	10.5	17.7	24	25	34	29	40
M10	15	21	35	48	50	67	59	81
M12	26	36	61	83	86.2	117	103	140
M14	42	58	101	132	136	185	162	220
M16	64	88	147	200	210	285	250	340
M18	89	121	202	275	287	390	346	470
M20	126	171	290	390	405	550	486	660
M22	169	230	390	530	559	745	656	890
M24	217	295	497	375	708	960	840	1140
M27	320	435	733	995	1032	1400	1239	1680
M30	435	590	995	1350	1401	1900	1681	2280
M33	590	800	1349	1830	1902	2580	2278	3090
M36	759	1030	1740	2360	2441	3310	2935	3980
M39	988	1340	2249	3050	3163	4290	3798	5150

The guides and ruler furnished below are designed to help you select the appropriate hardware.

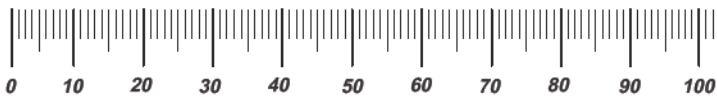

Nut, M8

Thread Diameter (mm)  
Inside Diameter (in)  
Threads per inch

Nut, 1/2-16

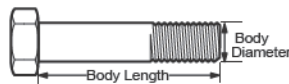

Screw, M8- 1.25 x 25

Thread Diameter (mm)  
Body Diameter  
Distance between threads (mm)  
Threads per inch  
Body Length (mm)  
Body Length (in)

Screw, 1/2- 16 x 2

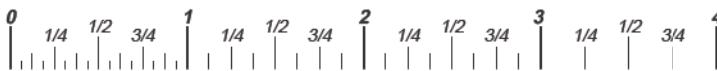

## Standard Hardware Sizing

When a washer or nut is identified as 1/2" (M8), this is the *Nominal size*, meaning the *inside diameter* is 1/2 inch (8mm metric thread diameter); if a second number is present it represents the *threads per inch* (distance between threads).

When bolt or capscrew is identified as 1/2 - 16 x 2" (M8 - 1.25 x 50 ), this means the *Nominal size*, or body diameter is 1/2 inch (8mm metric thread diameter), the second number, 16, represents the *threads per inch*, (1.25 thread diameter). The final number is the body length of the bolt or screw, 2 inches (50mm).

Torque Specification Chart FOR STANDARD MACHINE HARDWARE (Tolerance ± 20%)						
Hardware Grade	No Marks		SAE Grade 5		SAE Grade 8	
	SAE Grade 2		SAE Grade 5		SAE Grade 8	
Size Of Hardware	in/lbs ft/lbs		in/lbs ft/lbs		in/lbs ft/lbs	
		Nm.		Nm.		Nm.
8-32	19	2.1	30	3.4	41	4.6
8-36	20	2.3	31	3.5	43	4.9
10-24	27	3.1	43	4.9	60	6.8
10-32	31	3.5	49	5.5	68	7.7
1/4-20	66	7.6	8	10.9	12	16.3
1/4-28	76	8.6	10	13.6	14	19.0
5/16-18	11	15.0	17	23.1	25	34.0
5/16-24	12	16.3	19	25.8	29	34.0
3/8-16	20	27.2	30	40.8	45	61.2
3/8-24	23	31.3	35	47.6	50	68.0
7/16-14	30	40.8	50	68.0	70	95.2
7/16-20	35	47.6	55	74.8	80	108.8
1/2-13	50	68.0	75	102.0	110	149.6
1/2-20	55	74.8	90	122.4	120	163.2
9/16-12	65	88.4	110	149.6	150	204.0
9/16-18	75	102.0	120	163.2	170	231.2
5/8-11	90	122.4	150	204.0	220	299.2
5/8-18	100	136	180	244.8	240	326.4
3/4-10	160	217.6	260	353.6	386	525.0
3/4-16	180	244.8	300	408.0	420	571.2
7/8-9	140	190.4	400	544.0	600	816.0
7/8-14	155	210.8	440	598.4	660	897.6
1-8	220	299.2	580	788.8	900	1,244.0
1-12	240	326.4	640	870.4	1,000	1,360.0

## NOTES

- These torque values are to be used for all hardware excluding: locknuts, self-tapping screws, thread forming screws, sheet metal screws and socket head setscrews.
- Recommended seating torque values for locknuts:
  - for prevailing torque locknuts - use 65% of grade 5 torques.
  - for flange whizlock nuts and screws - use 135% of grade 5 torques.
- Unless otherwise noted on assembly drawings, all torque values must meet this specification.

## Common Hardware Types

Hex Head Capscrew



Washer



Carriage Bolt



Lockwasher

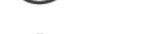

Hex Nut



## Wrench & Fastener Size Guide

1/4" Bolt or Nut Wrench—7/16"	5/16" Bolt or Nut Wrench—1/2"	3/8" Bolt or Nut Wrench—9/16"	7/16" Bolt or Nut Wrench (Bolt)—5/8" Wrench (Nut)—11/16"	1/2" Bolt or Nut Wrench—3/4"
M6 Bolt or Nut Wrench—10mm	M8 Bolt or Nut Wrench—13mm	M10 Bolt or Nut Wrench—17mm	M12 Bolt or Nut Wrench—19mm	M14 Bolt or Nut Wrench—22 mm



Not for  
Reproduction

**IT IS THE POLICY OF BRIGGS & STRATTON CORP. TO IMPROVE ITS PRODUCTS  
WHENEVER IT IS POSSIBLE AND PRACTICAL TO DO SO. WE RESERVE THE RIGHT TO  
MAKE CHANGES OR ADD IMPROVEMENTS AT ANY TIME WITHOUT INCURRING ANY  
OBLIGATION TO MAKE SUCH CHANGES ON PRODUCTS.**

**Briggs & Stratton Power Products Group**

---

12301 W. Wirth Street  
Wauwatosa, WI, 53222 USA

[www.BRIGGSandSTRATTON.com](http://www.BRIGGSandSTRATTON.com)  
[www.murray.com](http://www.murray.com)

© Copyright 2014 by Briggs & Stratton Corporation  
Milwaukee, WI, USA. All rights reserved